



**INTERNATIONAL JOURNAL OF ENGINEERING SCIENCES & RESEARCH  
TECHNOLOGY**

**Bone Quality Assessment Using MEMS Accelerometer**

**Mr.G.Manikandan\*, Mr. M. Suresh, K.Anuradha, Sijo Mathew**

\* Assistant Professor, Department of Electronics and Communication Engineering, Kodaikanal Institute of Technology, Tamilnadu, India

Assistant Professor, Department of Electronics and Communication Engineering, Kodaikanal Institute of Technology, Tamilnadu, India

Assistant Professor, Department of Computer science and Engineering,  
Kodaikanal Institute of Technology, Tamilnadu, India

Student, Department of Electronics and Communication Engineering,  
Kodaikanal Institute of Technology, Tamilnadu, India

---

**Abstracts**

Bone Mineral Density (BMD) is the amount of mineral per square centimeter of bone. Osteoporosis is defined as a systemic skeletal disease characterized by low bone mass and micro architectural deterioration of bone tissue, with a consequent increase in bone fragility and susceptibility to fracture. The prime motive of our work is to produce a cost effective medical instrument of the Bone Mineral Density (BMD). The developed instrumentation for assessing bone quality utilizes the principle of impulse response method. Our device consists of an automated hammer which knocks in the medial side of the proximal tibia. The stress wave is propagated through the bone and it is picked up by two triaxial MEMS accelerometers. Using this setup the acceleration magnitude has been measured for various subjects and the corresponding signals were obtained. The acquired signals are fed into the computer. We have collected the data from ten subjects with two different age groups and sex and found that the acceleration value obtained in the y-axis of second MEMS accelerometer of above 35 age is higher compared with the subjects below 35 years old. From the acquired and analyzed data, we found there is a significant change exists among the different age groups.

**Keywords:** MEMS Accelerometer.

---

**Introduction**

Bone quality is a composite of properties that make bone resist fracture such as its micro architecture accumulated microscopic damage the quality of collagen mineral crystal size and bone turnover. The most prevalent sequence is compression fractures of the vertebral bodies and fractures of the ribs, proximal femur (hip), humerus and distal radius. These fractures lead to deformity, loss of mobility, independence and even death. With increasing population of elderly women, the assessment and treatment of osteoporosis has become an important problem in clinical gynecology. Bone mineral loss occurs with aging, menopause, and disuse. The decrease in biomechanical strength of bone with age is much more pronounced than the loss of bone mass due to perforations during the remodelling process [3].

BMD measurements in conjunction with information about the structure and elastic properties of bone will result in a good indication of its mechanical condition and susceptibility to fracture. Moreover, during accidental impact, our bones are subjected to high strain rate loading. Since bone is a viscoelastic material [4], its

response to this type of loading cannot be assumed to be the same as predicted by a static analysis. Therefore, it is important to study dynamic characteristics of bone under normal and diseased state in order to understand its response to more realistic loading condition [5]. The change in Peak acceleration magnitude with age is also evaluated.

**Materials and method**

The automated hammer that runs by the DC motor hits the Medialis Condolosis region in the leg. The automated hammer is controlled by switches. When the hammer hits the Medialis Condolosis region, the impulse response travels through the bone of the leg. The MEMS accelerometers are placed below the lower portion of the leg. The experiment has been carried out for 10 women and men (age 40-50 years) and from men under the age group of 15-20 years.

Informed consent was obtained from all the subjects and they were found to be in good health from clinical evaluation and based on the answers to questionnaire.

The subjects were excluded from the study if any of the mechanical strength of the following conditions were present: inactivity or bed rest longer than 4 weeks within the past 12 months, subjects with fragility and atraumatic fractures, medical conditions affecting normal bone metabolism, and the subjects who are taking oral contraceptives or undergoing hormone replacement therapy. The stress waves are generated by the impact of hammer on the medial side of the proximal tibia at a distance of 4 cm from medial condyle. The impact force applied through impulse hammer is

standardized between 2-2.5N for each impact which is automatically done. The data is acquired into a computer after digitization using ADC through software at a sampling frequency of 100 KHZ per channel. The data is sampled for 5 seconds in which 4 impulses are applied and corresponding response data are acquired. USB-1208 Series modules are low-cost, PC-based analog and digital I/O devices. TracerDAQ® software included for acquiring and displaying data and generating signals

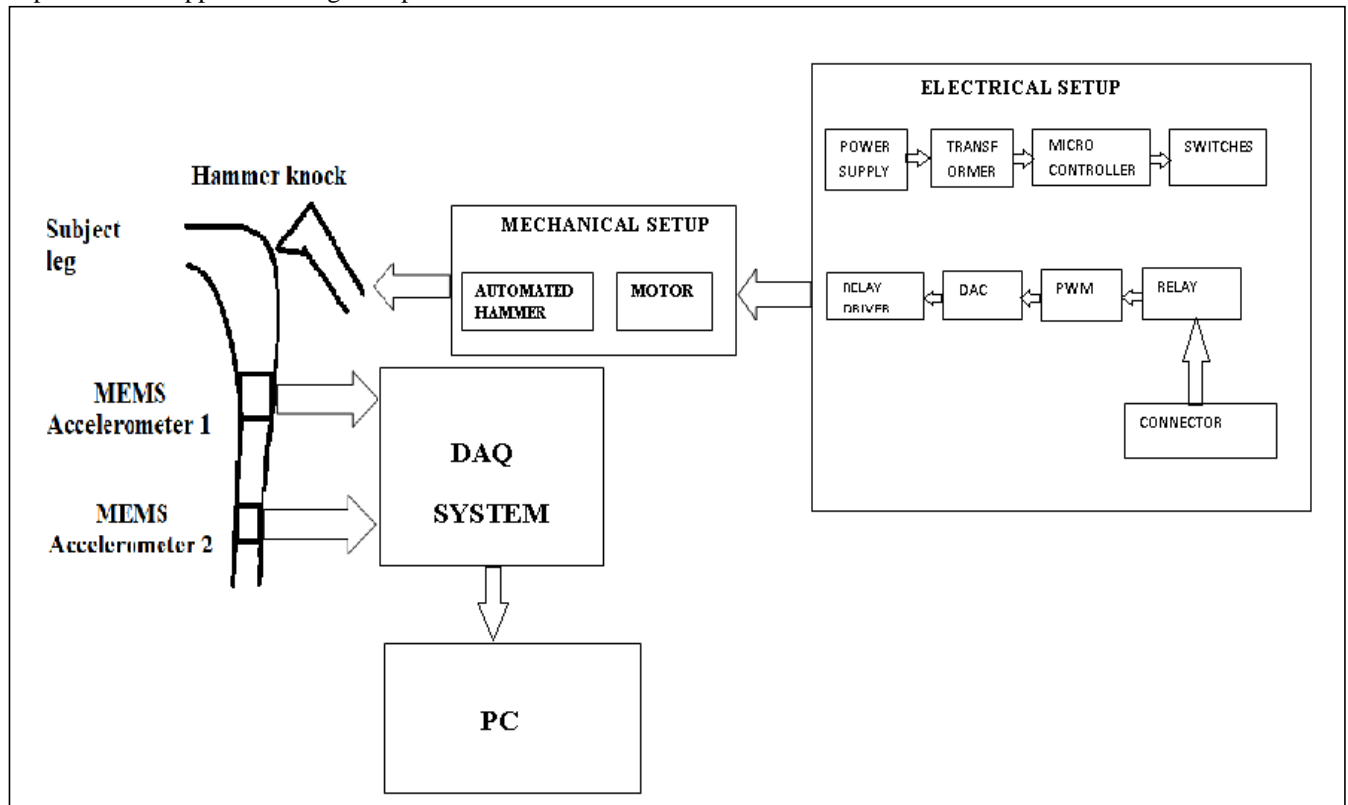

*Schematic block diagram of the hardware setup*



*Camera view of the hardware setup*

**Results**

In this study, ten subjects had participated with different age group such as below 35 and above 35 age group. The following parameters are made constant for all the subjects at the time of acquisition of reading.

- Sampling rate: 0.15
- Sampling count: 230
- Sampling interval: 0.01



**A typical impulse response of tibia of normal subject**

From the results obtained, we can conclude that the acceleration value obtained in terms of mille volts in channel 2 (Y-Axis of second accelerometer) is found to be high in Case of the above 35 age group compared to the below 35 age group. In general, four channels of the DAQ card are used to acquire the X, Y axes reading from the MEMS accelerometer. The Channel 0, and Channel 1 acquires X, Y axis of first MEMS accelerometer and Channel 2 and Channel 3 acquires the X, Y axis reading of the second accelerometer.

**Tabulation**

It was found that the variation is observed more clearly in the Y-axis than X-axis since the vibration from the automated hammer is transmitted vertically through the bone than in horizontal direction.

This data obtained from ten subjects is a preliminary work where for the determination of the abnormality, more number of data has to be collected from subjects. As a future work, the samples need to be obtained from around 50 subjects of varying age group and the statistical analysis to be done. Then the output will highly reliable and can be used also as a diagnosing tool for bone quality

**Conclusion**

The impulse response technique for monitoring the stress wave propagation in tibia bone has been effectively used in the assessment of bone quality. The technique gives a better understanding of the dynamic behaviour of bone under impact force. The study is non-invasive, reliable, easy to operate, inexpensive and has diagnostic potential in the assessment of bone quality. For this careful analysis and comparison of the data obtained from the subjects has to be done for

Sl.no	Subjects Details	Accelerometer-1 output (Max)	Accelerometer-2 output (Max)
1.	<b>Men (15-20)</b>	3.0986	1.4351
2.	<b>Women (15-20)</b>	1.7428	0.9744
3.	<b>Men (45-50)</b>	2.5747	1.0590
4.	<b>Men (Dia.-45-50)</b>	1.6174	1.5279
5.	<b>Women (45-50)</b>	2.0781	1.1746
6	<b>Women (Dia.45-50)</b>	3.2633	0.5723

distinguishing osteoporotic and diabetic conditions. If this is achieved, our novel diagnostic tool will be a multi-purpose diagnosing tool which will be capable of diagnosing bone quality as well as diabetes non-invasively.

**References**

1. World Health Organization: International Classification of Impairments, Disabilities and Handicaps. WHO, Geneva, Switzerland, 1980.
2. N. Dorothy, R. Molloy and M. Kleerekoper, —Prevalence of osteoporosis in women referred for bone density testing, J. Clin. Densitometer, 1, 5- 11, 1998.
3. Li. Mosekilde, Bone remodeling, pp.343-356, in Le Mosekilde and Li Mosekilde (Ed.) Complexity Chaos and Biological Evolution, Plenum Press, New York, 1991
4. R.S. Lakes and S. Saha, —Long term torsional creep in compact bone. Biomech. Engng. 102, 178- 180, 1980.
5. R.R. Pelker and S. Saha, —Stress wave propagation in bone. Biomechanics, 18, 745-753, 1983.

6. Evaluation and Assessment of Osteoporosis by Quantitative Ultrasound (Kaufman and Einhorn, 1993)
7. S. Cheng, J. Timonen and H. Suominen —Elastic wave propagation in bone in vivo: methodology of Biomechanics 28,471-478, 1995
8. P.D. Delinas, A. Schlemmer, E. Gineyts, B. Riis and C.Christiansen (1991) —Urinary excretion of pyridinoline cross links correlates with bone turnover measured on iliac crest biopsy in patients with vertebral osteoporosis, J. of Bone Min. Res., 6,639-644, 1991
9. J. A. McGowan —Osteoporosis: assessment of bone loss and remodeling, Aging - Clinical and Experimental Research, 5, 81-93, 1993.
10. M.S. Holi and S. Radhakrishnan, —Comparison of ultrasound and dual energy x-ray absorptiometry (DEXA) methods in estimation of low bone mass for the assessment of osteoporosis fracture risk in Indian men and women, Acta of Bioeng. And Biomech. 4, 396-397, 2002.
11. In vivo Assessment of Osteoporosis by Impulse Response and Stress Wave Propagation Technique (M.S.Holi, 2003)